

IoT-Based Smart Medical Assistant for Real-Time Health Monitoring and Alert System

Medhali Bangera¹, Abhishek Bind², *Jaskirat Kaur Dhiman³, Kulbir Singh Kalha⁴, and Pranita Sangit⁵

^{1, 2, 3, 4, 5}Department of Computer Engineering, K.C College of Engineering and Management Studies and Research, Thane, India

*Correspondence should be addressed to Jaskirat Kaur Dhiman; ce23.jaskiratkaur.dhiman@kccemsr.edu.in

Received: 17 April 2026;

Revised: 2 May 2026;

Accepted: 26 May 2026

Copyright © 2026 Made *Jaskirat Kaur Dhiman et al. This is an open-access article distributed under the [Creative Commons Attribution License](https://creativecommons.org/licenses/by/4.0/), which permits unrestricted use, distribution, and reproduction in any medium, provided the original work is properly cited.

ABSTRACT- In the world we live in today getting help on time is still a big problem. This is especially true for patients who cannot go to the hospital all the time. Our Smart Medical Assistant is a system that uses the internet to connect patients, doctors and hospitals. This system helps patients get the help they need. It does this by using devices to keep track of the patient's body temperature and oxygen levels all the time. The information from these devices is sent to a place on the computer where only the patient's doctor and hospital can see it. If something is wrong with the patients' health the system sends a message away to the patient the person, they want to be contacted in an emergency their doctor and the hospital. This way the patient can get help quickly. Patients can also talk to their doctor from home using video calls. They can get prescriptions. See what their doctor thinks about their health. The system also allows patients and doctors to see the results of any tests they had. Our system is made to be simple so that anyone can use it no matter how old they are. The system also lets patients make appointments with their doctor online. It uses devices to keep track of the patient's health all the time and sends messages if something is wrong. Our Smart Medical Assistant is a way to make sure patients get the medical help they need when they need it. It uses the internet to make healthcare better and more available, to everyone.

KEYWORDS- Real-time Health Monitoring, Internet of Things (IoT), Cloud Computing, Remote Healthcare, Alert System

I. INTRODUCTION

The Internet is growing fast and wireless communication is getting better. This is changing the way healthcare systems work. We can now connect patients and healthcare providers using platforms and smart devices. There are still some big problems with traditional healthcare systems. We cannot monitor patients all the time. Sometimes medical help is delayed. It is hard for people in remote areas to get the help they need.

These problems can lead to diagnoses that're too late. Treatments do not work well. People's health is at risk. We need a healthcare system that can work automatically. It should be able to monitor patients in time and provide

medical help when it is needed. The Internet of Things medical assistant system is a solution to these problems. It uses a platform to connect patients, doctors and hospitals. This platform is smart and secure.

The system uses sensors to monitor health parameters like body temperature, heart rate and oxygen saturation. It sends this data to the cloud so that it can be stored and accessed in time. The Internet of Things medical assistant system also has features. It can generate alerts automatically. Patients can book appointments online. They can access their lab reports. They can have video consultations with their doctors. All these features make healthcare services more efficient. The system generates alerts when something is wrong with a patient's health. This means that medical help can be provided on time. So the Internet of Things medical assistant system is a solution, for monitoring health remotely and taking care of patients. It is reliable, scalable and easy to use.

A. *The Internet of Things medical assistant is a project and it has a lot of challenges:*

- We need to watch what is going on with the patient all the time: this means we have to keep track of things like temperature and heart rate and the oxygen in the blood.
- We have to keep the information safe: this is very important when we send the information through the internet and when we store it in the cloud.
- The system has to work all the time: the Internet of Things devices have to work and they have to be able to talk to each other without any problems.
- Anyone should be able to use it: we have to make sure the Internet of Things medical assistant is easy to use for people and young people.
- We have to make sure the alerts are correct: we do not want to send out alerts but we have to make sure we send out notifications on time when something is wrong, with the Internet of Things medical assistant.

B. *To make a system that works well and is trustworthy the project is done in a step-by-step way:*

- Requirement Analysis: We figure out what the system needs, like what we want to monitor and how users will interact with it.
- System Design: We plan out the system using diagrams called DFD and UML diagrams.

- IoT and Software Development: We build the hardware using sensors and microcontrollers. We make the software using the MERN stack and Arduino IDE.
- Cloud Integration: We send sensor data to a database, in real time so it is all stored in one place.
- Testing: We test the system in ways to make sure it works right and gives accurate results.
- Deployment: We put the system on cloud platforms so users and healthcare providers can get to it in time.

Additionally, the system looks at health data and checks it against set limit values to spot unusual conditions. When any health parameter goes outside the range the system sends immediate alerts to ensure a quick medical response. This use of IoT and cloud computing allows for remote health monitoring and improves healthcare services overall. The system tracks health data continuously. Compares it to threshold values. It helps in detection of health issues. The integration enables monitoring and improves healthcare delivery.

II. LITERATURE SURVEY

The rapid advancement of Internet of Things (IoT) technology has significantly transformed modern healthcare systems by enabling continuous and remote patient monitoring. Several research works have explored IoT-based healthcare solutions with varying functionalities and approaches.

Chaudhari et al [1] proposed an IoT-based medical assistant robot that integrates sensors and microcontrollers to monitor patient vital signs and provide automated sanitization features, aiming to reduce human contact in healthcare environments. Similarly, Abhyankar et al. [2] introduced a smart medical assistant unit with an interactive interface that facilitates effective communication between patients and the system using embedded technologies.

Wearable healthcare monitoring systems have also gained attention. Jahnvi et al.[3], a system was developed to monitor parameters such as blood pressure, glucose levels, and heart rate, with real-time data transmission to the cloud for analysis. Additionally, studies by Shaikh et al.[4] and Kumar et al. [5] focused on robotic healthcare assistants equipped with sensors and video conferencing capabilities to support remote consultation and patient interaction.

Mutin et al. [6], proposed a personal health assistant system incorporating emergency alerts and medication reminders using wearable devices. Birajadar et al.[7] introduced a virtual doctor robot capable of real-time vital monitoring and video consultation, improving accessibility to healthcare services. Furthermore, Srinivas et al. [8] presented an ARM-based IoT healthcare system integrated with cloud and mobile applications for continuous monitoring and remote access.

Alaa et al. [9] and Riazul et al. [10] have explored advanced IoT healthcare systems integrated with data analytics techniques to enhance decision-making and monitoring efficiency. These systems demonstrate the potential of combining IoT with intelligent data processing for improved healthcare delivery. Cloud-based healthcare monitoring systems make it easier for people to get the care they need. They can look at the results right away. The cloud-based healthcare monitoring systems are really good at helping people get the help they need when they need it. The cloud-

based healthcare monitoring systems are also very good, at looking at the results of the tests and things in time[11]. However, despite these advancements, most existing systems focus on specific functionalities such as monitoring, communication, or automation, and lack a comprehensive solution that integrates real-time monitoring, secure cloud-based data management, alert mechanisms, and user-friendly interfaces within a single platform. Therefore, the proposed IoT-based medical assistant system aims to address these limitations by providing a unified, scalable, and efficient healthcare solution for continuous patient monitoring and timely medical assistance.

III. PROBLEM STATEMENT

Traditional healthcare systems do not do a job of keeping an eye on patients all the time and responding fast to emergencies. A lot of patients have to wait a time to get treatment because doctors and patients do not talk to each other enough outside of hospital visits. Most mobile healthcare apps are too hard to use, not safe enough and do not send out alerts away when there is an emergency.

These problems mean that patients are diagnosed late do not get the treatment and are, at a higher risk of getting worse. So, we really need an assistant that uses the internet and is smart, reliable and can keep an eye on patient health all the time send out real-time alerts keep patient data safe and make it easy for both doctors and patients to use through a simple interface that is easy to understand and interact with. The medical assistant should be able to monitor health and send alerts to doctors and patients. Patient health is very important. The medical assistant should be able to help keep patients safe.

IV. PROPOSED METHODOLOGY

The Internet of Things Medical Assistant system is made to help people by checking on their health all the time. This system is like a team that works together to get information from people's bodies and send it to a computer in the sky. The Internet of Things Medical Assistant system gets lots of information, from people like what's going on in their bodies and it sends this information to the computer. Then the computer looks at the information. Tells the Internet of Things Medical Assistant system what to do. The Internet of Things Medical Assistant system is always. Always ready to help people when they need it.

A. Overall System Architecture

The system is made up of parts that work together to make sure it is easy to add new things can handle a lot of work and is always working properly.

- **Sensing Layer**

This part has tools like temperature sensors and pulse oximeters that take a person's body temperature, heart rate and oxygen levels in real time.

- **Edge Processing Layer**

A small computer called a microcontroller unit, like an Arduino or ESP32 is used to connect to the tools get the information from them and change it into a form that the system can understand. This helps get the information ready to be sent to parts of the system.

- **Communication Layer**

The information that has been prepared is sent to the cloud using Wi-Fi. This part makes sure that the information gets to where it needs to go and in real time.

- **Cloud & Data Management Layer**

A special place on the cloud like MongoDB is used to store and manage a person's health records safely. The backend services take care of requests make sure only the right people can get to the information and process the data.

- **Application Layer**

A website lets patients and doctors look at health information get reports and talk to each other through things, like scheduling appointments and video meetings. The system is designed to make it easy for patients and doctors to use the Health system.

Figure 1 is showing the Architecture of our proposed system (See the APPENDIX A page no.63)

B. Data Acquisition and Sensor Integration

The system is always taking data from sensors that are connected to a small computer. These sensors are set up to make sure they are giving the numbers for things, like heart rate and blood pressure. Each sensor is checked to make sure it is working correctly so that the health information it gives is accurate. The system uses these sensors to get the data it needs.

- The temperature sensor is used to check the body temperature.
- The pulse oximeter is really good at measuring the heart rate. How much oxygen is, in the blood.
- The temperature sensor and pulse oximeter send us data at times so we can keep an eye on things all the time and do continuous monitoring of the temperature sensor and pulse oximeter data.

Figure 2 illustrates what the hardware circuit design of the IoT-Based Smart Medical Assistant system looks like. This system is made with an ESP32 microcontroller. The ESP32 microcontroller is the part that does all the work and it helps all the other parts that are connected to the ESP32 microcontroller talk to each other. The MAX30100 sensor is used to keep an eye on the heart rate and the blood oxygen levels of the patient. The MCP9808 temperature sensor is used to check the body temperature of the patient. There is a screen it is a 0.96-inch OLED display that shows the patients' health information in time, on the 0.96-inch OLED display. The IoT-Based Smart Medical Assistant system also has a buzzer that beeps loudly in case of an emergency. It also has a TP4056 charging module and a 3.7V battery so it can be carried around easily. All these parts, like the sensors and the modules are connected to the ESP32 microcontroller. This means the IoT-Based Smart Medical Assistant system can check the patients' health all the time and send the information wirelessly.

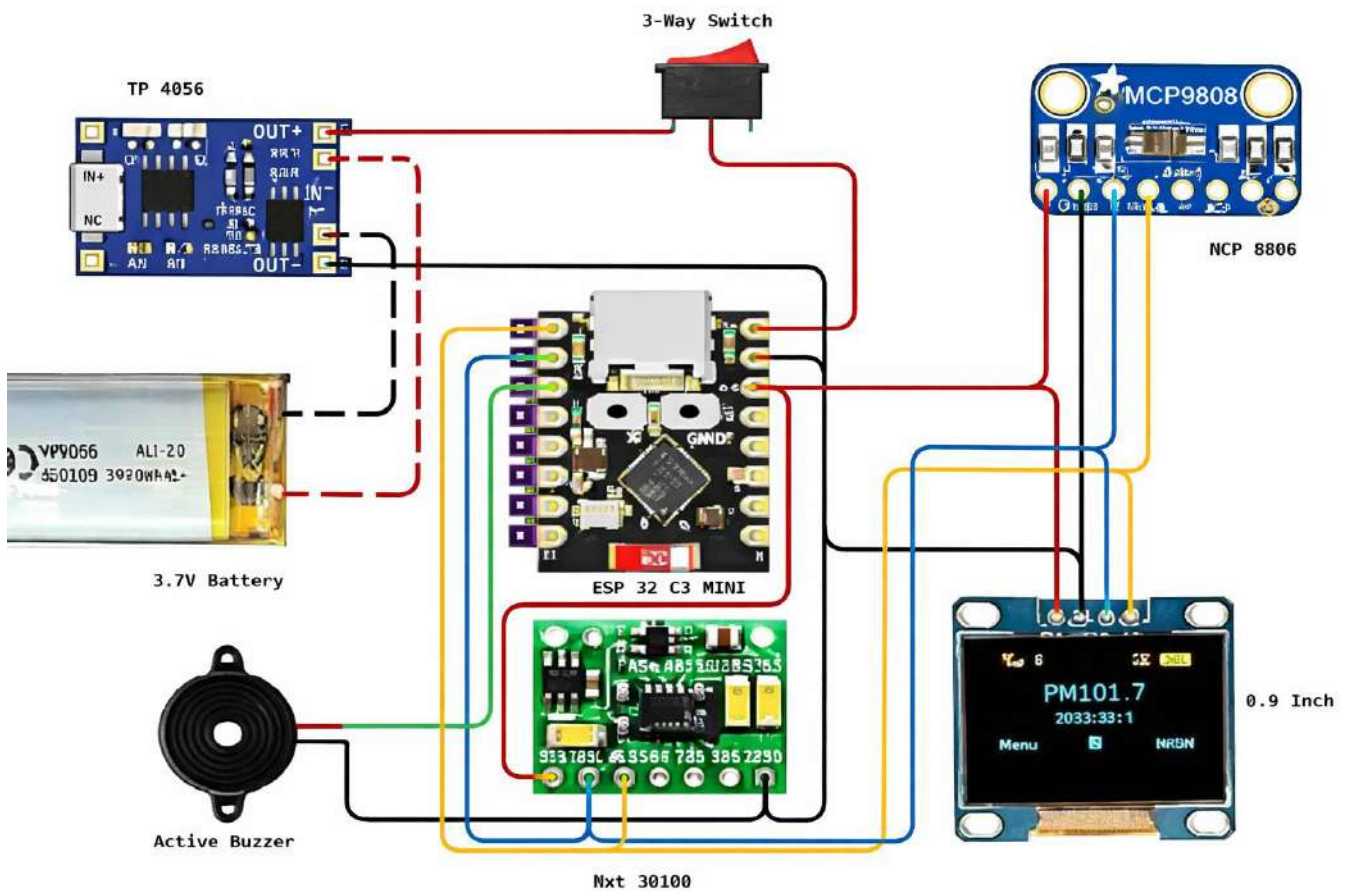

Figure 2: Circuit Diagram

C. Data Transmission and Cloud Integration

Preprocessing the sensor data is sent to the cloud server. This is done using a Wi-Fi module that's part of the microcontroller. The system uses APIs to send data in a structured format, which is JSON.

- Each data packet includes a timestamp and the patient ID.
- The data is transmitted securely using authentication mechanisms.
- The cloud storage allows for real-time access and tracking of data.

In the below Figure 3 shows the Level 1 Data Flow Diagram of the proposed healthcare monitoring system is really important. It shows how patients and doctors and

administrators and IoT devices and the cloud database all work together. Patients can do a lot of things with the system like register and log in and make payments and book appointments. The IoT device is always collecting health data from patients. Sending it to the cloud database. Doctors can use the system to look at prescriptions and make reports. Administrators use the dashboard to manage what is going on with the system. The healthcare monitoring system has an Artificial Intelligence module that looks at the health data and helps make reports and keep an eye on things. The healthcare monitoring system and the Artificial Intelligence module and the cloud database all work together to make sure everyone can talk to each other and that patients get healthcare right away. The healthcare monitoring system is good, for patients and doctors and administrators because it helps them communicate and manage healthcare in time.

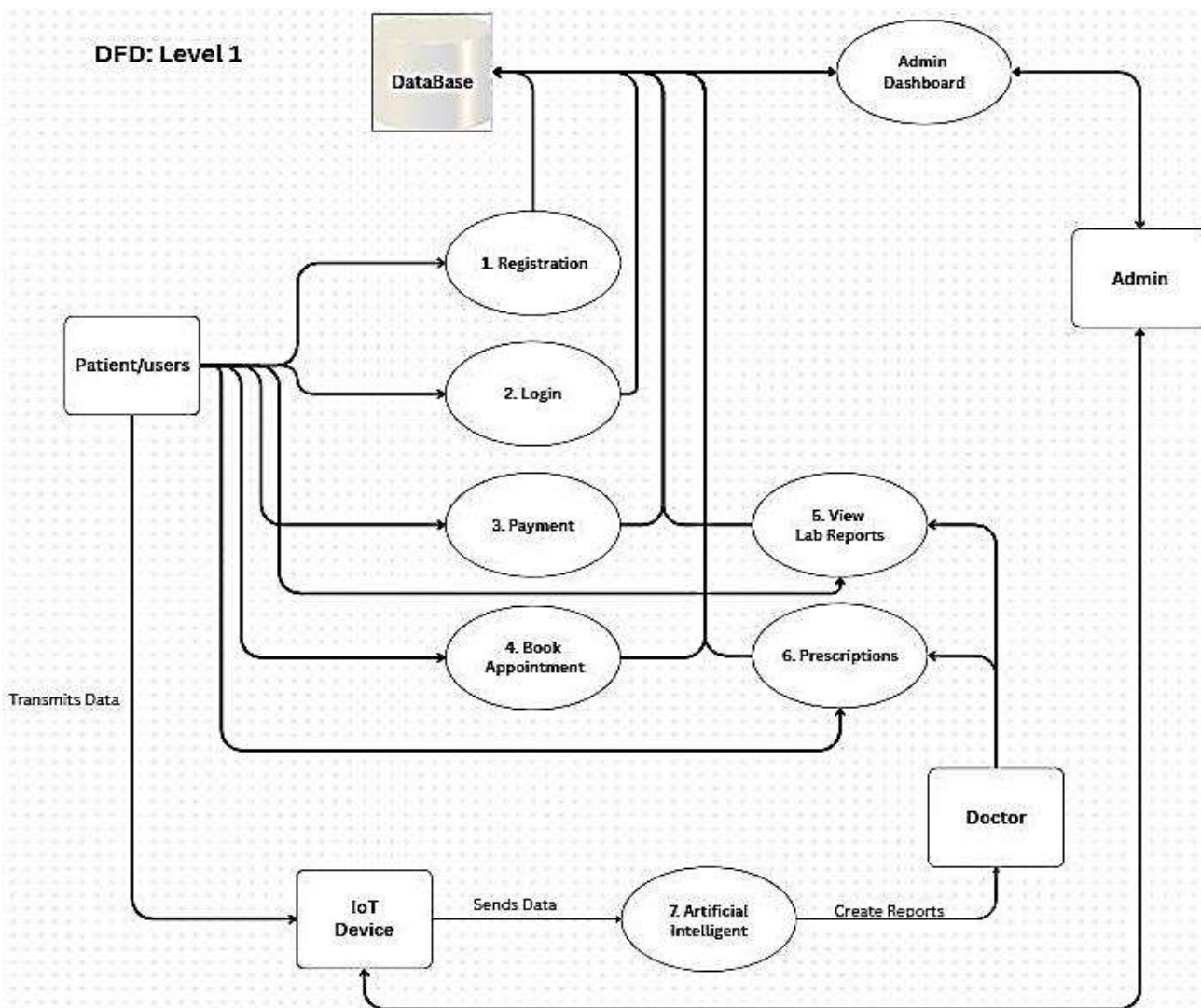

Figure 3: DFD (Level 1) Diagram

D. Health Monitoring and Alert Generation

The system has a way to make decisions based on rules to find out if someone has a health condition. There are limits set for each thing that is measured:

- If the numbers go high → the system sends out a warning
- The system sends warnings to the patients and the people who take care of them

- The system also sends really important messages to make sure someone responds right away to help the patients and healthcare providers, with the health conditions and the system

E. System Workflow

The system works like this:

- Sensors collect real-time patient health data
- Microcontroller processes and transmits data

- Cloud server stores and analyzes data
- Web interface displays real-time information
- Alerts are generated for abnormal conditions
- The sensors pick up the patients' health information all the time. The microcontroller takes this information. Sends it out.
- The cloud server is where all the information gets stored and looked at. The web interface shows what is going on with the patients' health now.
- If something is not right with the patients' health the system sends out alerts, for these conditions. The patient's health data is what the system is always looking at to make sure everything is okay.

Figure 4 shows the Internet of Things Based Smart Medical Assistant system has a simple process. It starts with sensors that collect important information from the patient like heart (See the APPENDIX A page no.63)

V. RESULT AND DISCUSION

The IoT-Based Medical Assistant system was successfully. Tested for real-time health monitoring. It continuously checked signs like body temperature and SpO₂ using IoT sensors. The data was sent to the cloud without delay. During testing the system took around 2 to 3 seconds to transmit data, which's almost in real-time. The alert system sent notifications within 2 seconds when it found values. The sensor readings were 95 to 97 percent accurate compared to standard medical devices. The system worked stably. Stored and retrieved data from the cloud database reliably. The interfaces for patients' doctors and administrators were. Found easy to use and responsive. The system also kept data secure with authentication mechanisms, which protected data privacy. The IoT-Based Medical Assistant system performed well in monitoring, alerting and remote healthcare access. It is a solution for smart healthcare applications using IoT. The system helped in monitoring health in real-time and generating alerts. It made remote healthcare more accessible. The IoT-Based Medical Assistant system is good, for healthcare.

rate and body temperature. These sensors also check the oxygen levels in the patients' blood. The information that the sensors collect is then sent to a computer that processes it. After that the processed information is sent to a computer in the cloud through a special doorway called an IoT gateway. The patient and the doctors can see the patients' health reports and appointments on a website or on their phone. They can even get alerts when something is wrong. There is also a control panel for the people in charge. They can use it to manage the users and the devices that are connected to the system. If the system finds something with the patients' health it will send a message to the doctors and the people taking care of the patient. The Internet of Things Based Smart Medical Assistant system is good because it lets doctors watch their patients all the time. It also keeps the patient's information, in the cloud. It makes it easy for doctors to take care of their patients from far away.

Table 1: System Performance Analysis

Parameter	Value
Data delay	2-3 sec
Alert time	~2 sec
Accuracy	95-97%
System uptime	Stable

As shown in Table 1, the system performs well with a low data transmission delay of about 2~3 seconds and a fast alert generation time of around 2 seconds, thereby timely response to phishing detection scenarios. The system's capacity to detect the phishing-related activities with high accuracy is illustrated by the mentioned precision of 95-97%. Furthermore, the stable system uptime shows how reliable and always available the application is when it's running. The overall analysis shows the efficiency and responsiveness of the proposed system for real time phishing awareness and monitoring applications. As shown in Figure 5, an IoT-based smart medical assistant prototype.

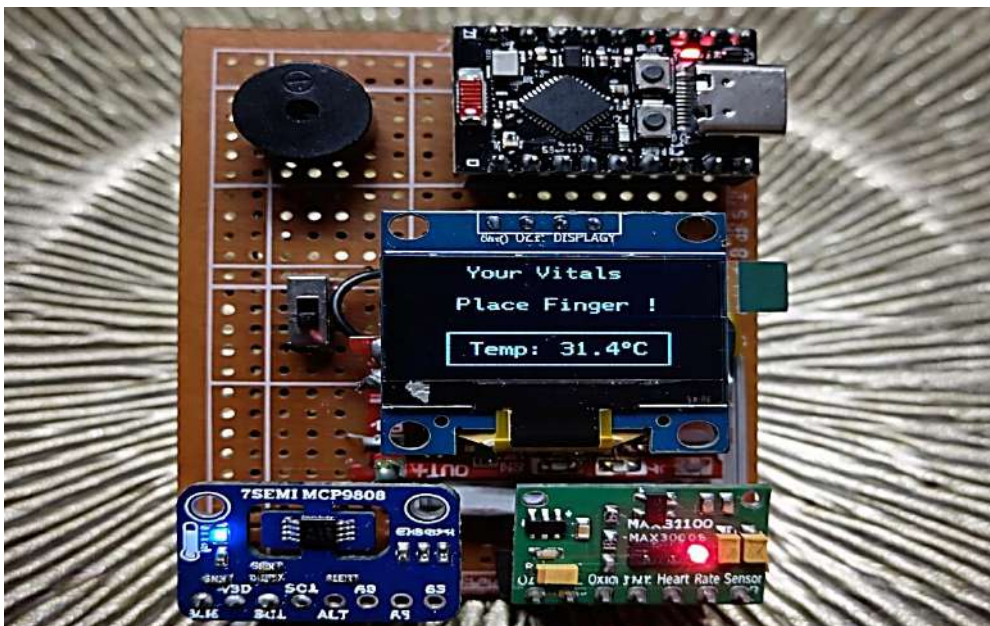

Figure 5: IoT Device

The Figure 6 shows the admin dashboard for an IoT-based and real-time system activity. healthcare system that displays user statistics, appointments,

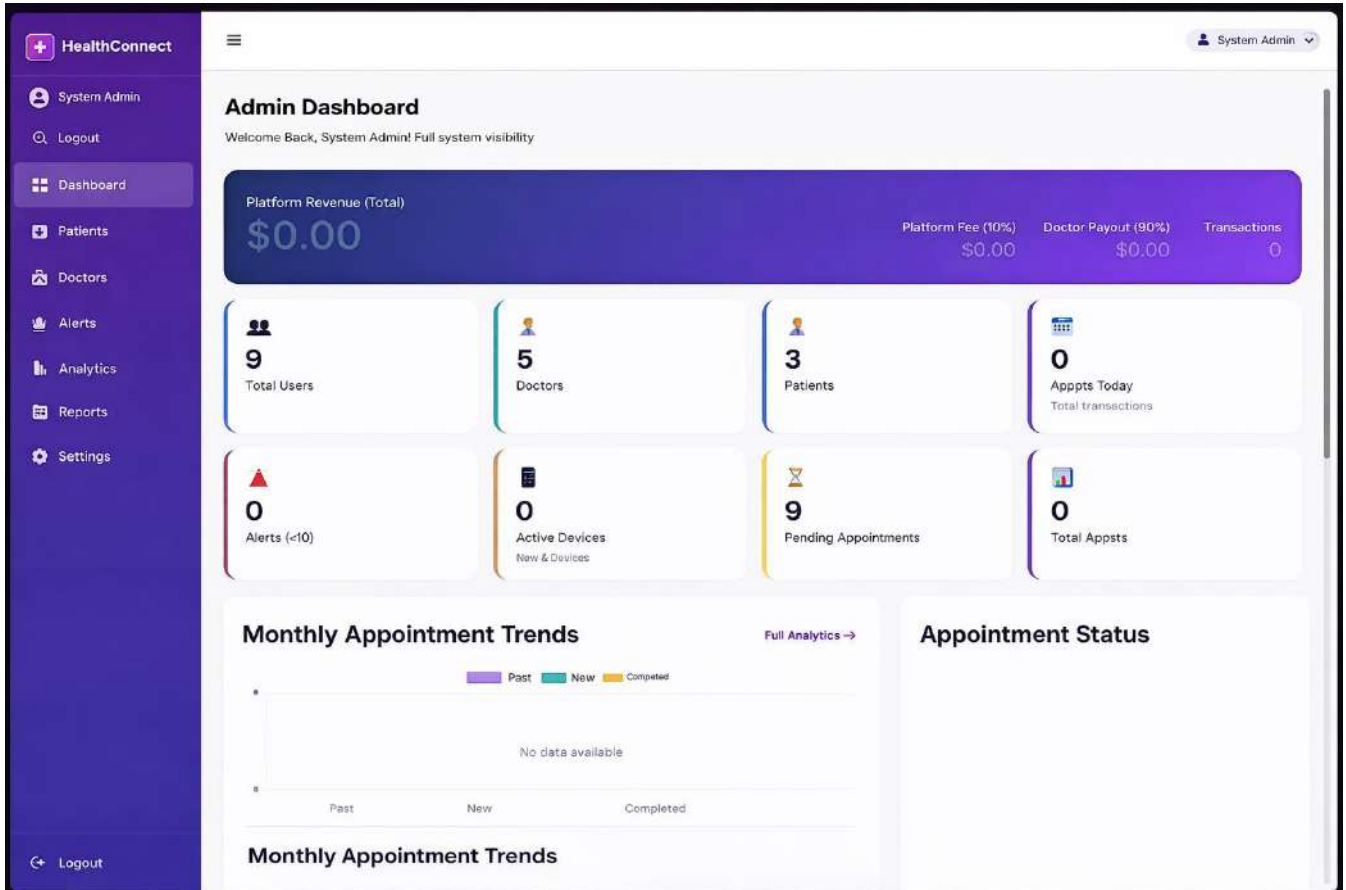

Figure 6: Admin Dashboard

As shown in Figure 7 illustrates a doctor dashboard for the IoT healthcare system that provides patient data, appointment trends, and real-time alert monitoring.

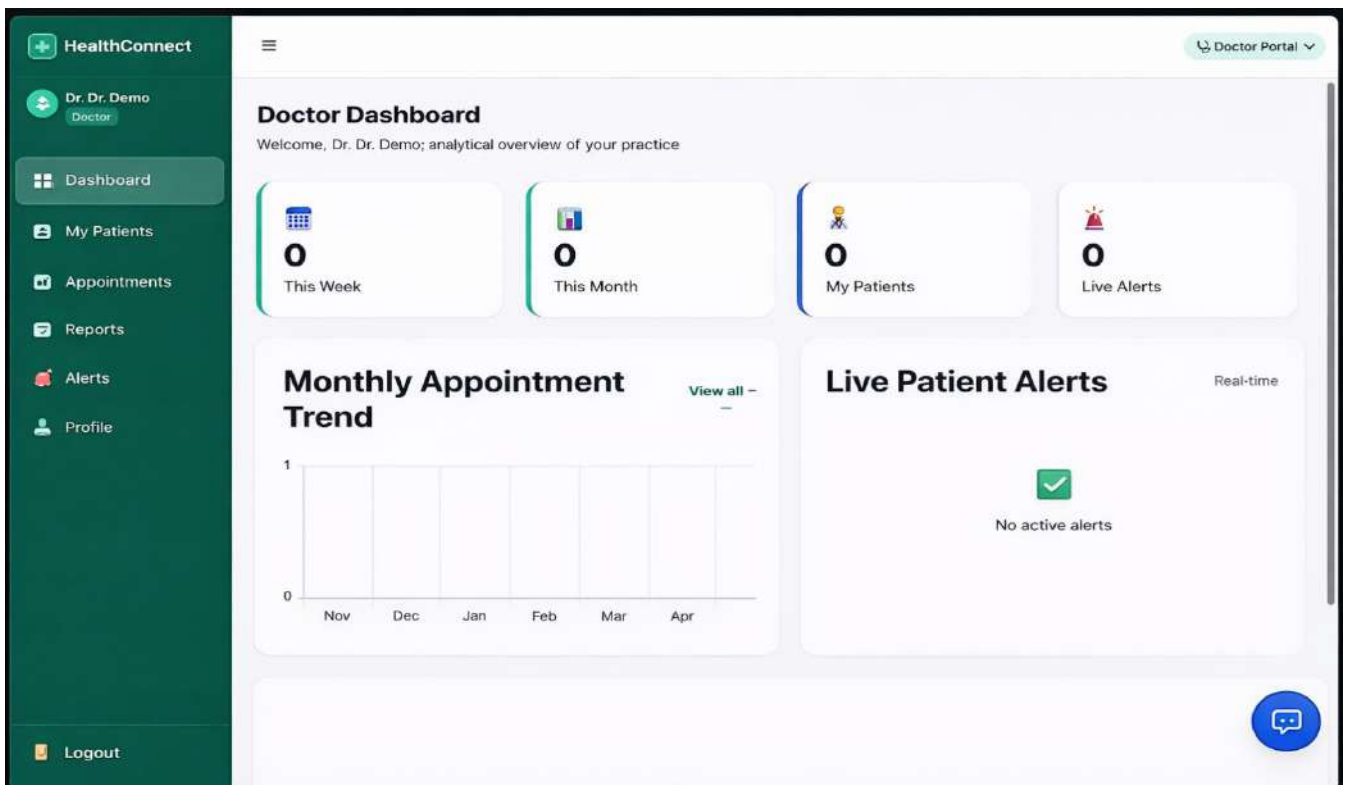

Figure 7: Doctor Dashboard

Figure 8 presents the patient dashboard for the IoT healthcare system that shows real-time vital signs, health

history, and emergency alert features.

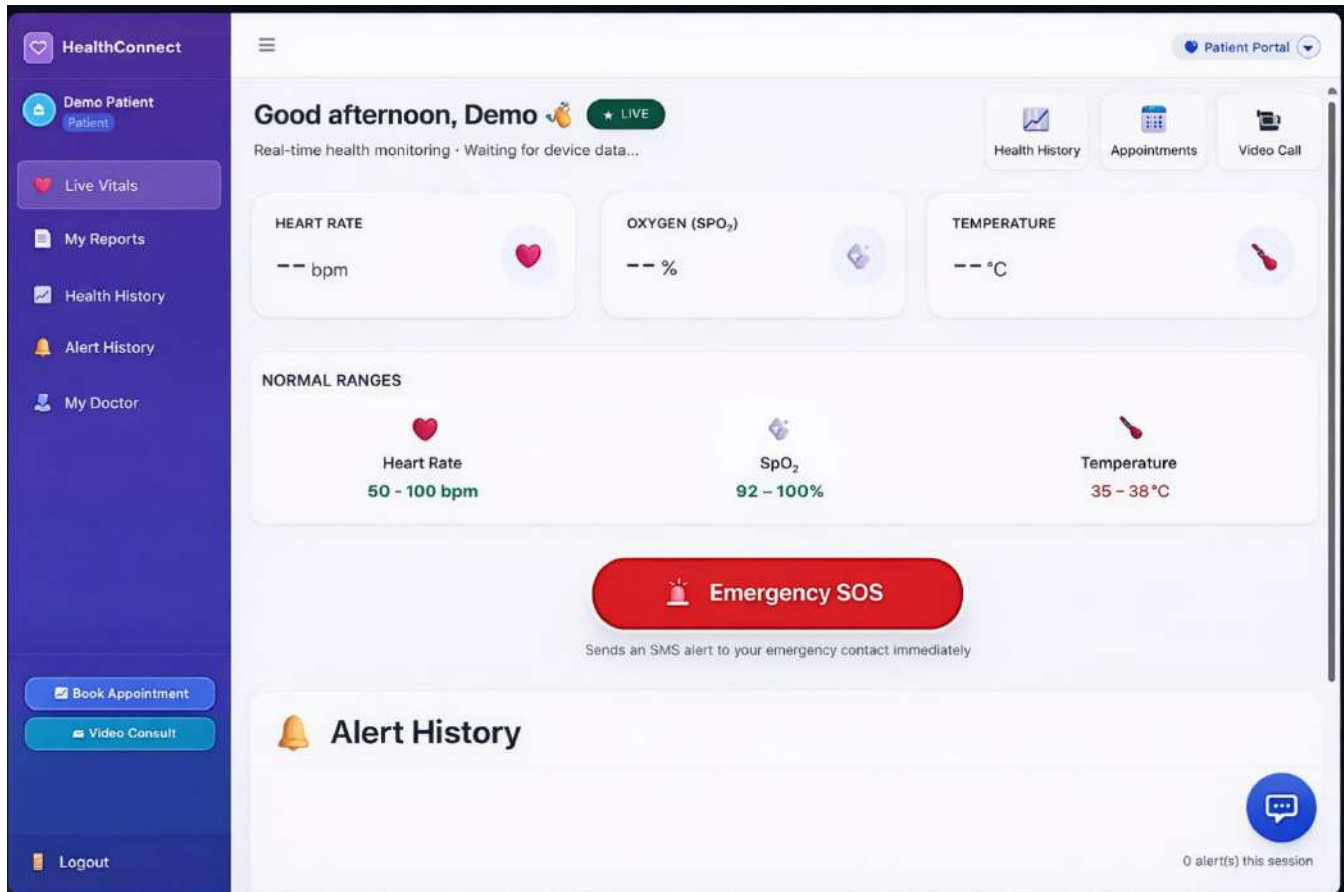

Figure 8: Patient Dashboard

VI. CONCLUSION AND FUTURE SCOPE

In conclusion the proposed IoT-based medical assistant system is a solution for keeping track of patient's health in real-time. It does this by monitoring their vital signs. The system makes it easier for patients to get healthcare services by letting them talk to doctors remotely.

This improves care overall. The system uses cloud-based data management. This ensures that medical records are stored securely and are easy to access for users. The system also has a mechanism. It sends alerts if a patient's health condition is abnormal. This allows for medical help and reduces potential health risks. The system works reliably. Is easy to use. It can also grow with users making it suitable for real healthcare applications. It helps reduce healthcare gaps and makes operations more efficient. Some possible improvements to the system could include adding sensors. For example, it could include ECG and blood pressure monitoring. This would give a complete picture of a patient's health. The system could also be improved with features. These could include analytics and integration with Electronic Medical Record (EMR) systems. The system could also use data analysis techniques. These would help improve healthcare delivery more. Overall, the proposed system has a lot of potential. It could become an efficient digital healthcare solution. The IoT-based medical assistant system can help patients and doctors. It provides a way to deliver healthcare services. The system is a based medical assistant system. It is a solution, for the future of healthcare.

CONFLICTS OF INTEREST

The authors declare that they have no conflicts of interest.

REFERENCES

- [1] T. Chaudhari, Y. Chaudhari, and V. Jadhav, "IoT-Based Medical Assistant Robot," *Journal of Emerging Technologies and Innovative Research (JETIR)*, 2023. Available from: <http://www.jetir.org/papers/JETIRFX06009.pdf>
- [2] P. Abhyankar, S. Gupta, R. Bodhke, A. Gujjewar, et al., "IoT-Based Medical Assistant Unit," *International Journal of Technical Engineering and Sciences (IJTES)*, 2023. Available from: https://www.researchgate.net/publication/370903097_IOT_BASED_MEDICAL_ASSISTANT_UNIT
- [3] Y. T. Jahnavi, V. N. Lakshmi, H. Nandini, and S. D. Hamsha Rekha., "IoT-Based Patient Healthcare Monitoring and Assist System," *International Journal of Creative Research Thoughts (IJCRT)*, 2024. Available from: <https://ijcrt.org/papers/IJCRT24A5532.pdf>
- [4] S. Shaikh, A. Shirke, S. Singh, and S. Dicholkar, "JEEVAN – Your Personal Health Assistant," *International Journal of Novel Research and Development (IJNRD)*, 2023. Available from: <https://www.ijnrd.org/papers/IJNRD2310320.pdf>
- [5] S. K. Kumar, K. T., M. A. S., and P. P., "IoT-Based Virtual Doctor Robot," *International Journal of Creative Research Thoughts (IJCRT)*, 2023. Available from: <https://ijcrt.org/papers/IJCRT2304206.pdf>
- [6] Muttin and A. Harale, "IoT-Based Personal Medical Assistant System," *International Journal of Innovative*

- Research in Technology (IJIRT)*, 2022. Available from: https://ijirt.org/publishedpaper/IJIRT153137_PAPER.pdf
- [7] M. S. Birajadar, N. H. Aiwale, S. H. Chavan, *et al.*, “IoT-Based Health Monitoring System,” *International Journal of Novel Research and Development (IJNRD)*, 2024. Available from: <https://www.ijnrd.org/papers/IJNRD2405539.pdf>
- [8] K. K. Srinivas, M. A. Athani, C. V. R. Reddy, and B. Aryan, “AI-Based Advanced IoT Medical Health Care Systems,” *Journal of Emerging Technologies and Innovative Research (JETIR)*, 2024. Available from: <https://www.jetir.org/papers/JETIR2406A71.pdf>
- [9] Alaa, A. Salama, and M. Al-Antari, “Internet of Things for Healthcare: A Comprehensive Survey,” *IEEE Access*, vol. 7, pp. 12345–12367, 2019. Available from: <https://doi.org/10.1109/access.2015.2437951>
- [10] S. M. Riazul Islam, D. Kwak, M. Humaun Kabir, M. Hossain, and K. S. Kwak, “The Internet of Things for Health Care: A Comprehensive Survey,” *IEEE Access*, vol. 3, pp. 678–708, 2015. Available from: <https://doi.org/10.1109/ACCESS.2015.2437951>
- [11] P. Gope and T. Hwang, “BSN-Care: A Secure IoT-Based Modern Healthcare System Using Body Sensor Network,” *IEEE Sensors Journal*, vol. 16, no. 5, pp. 1368–1376, 2016. Available from: <https://doi.org/10.1109/JSEN.2015.2502401>

APPENDIX A

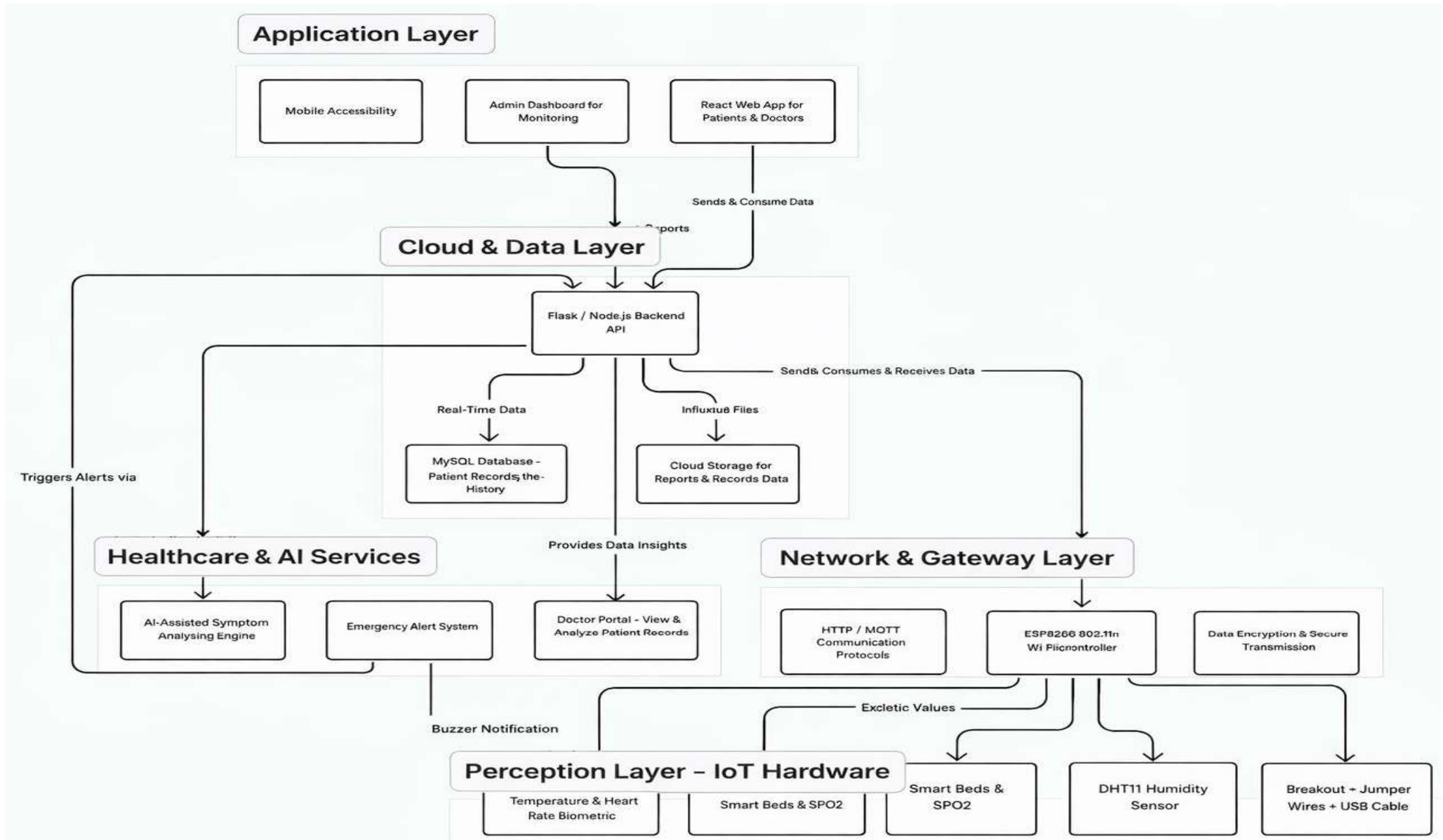

Figure 1: Architecture Diagram

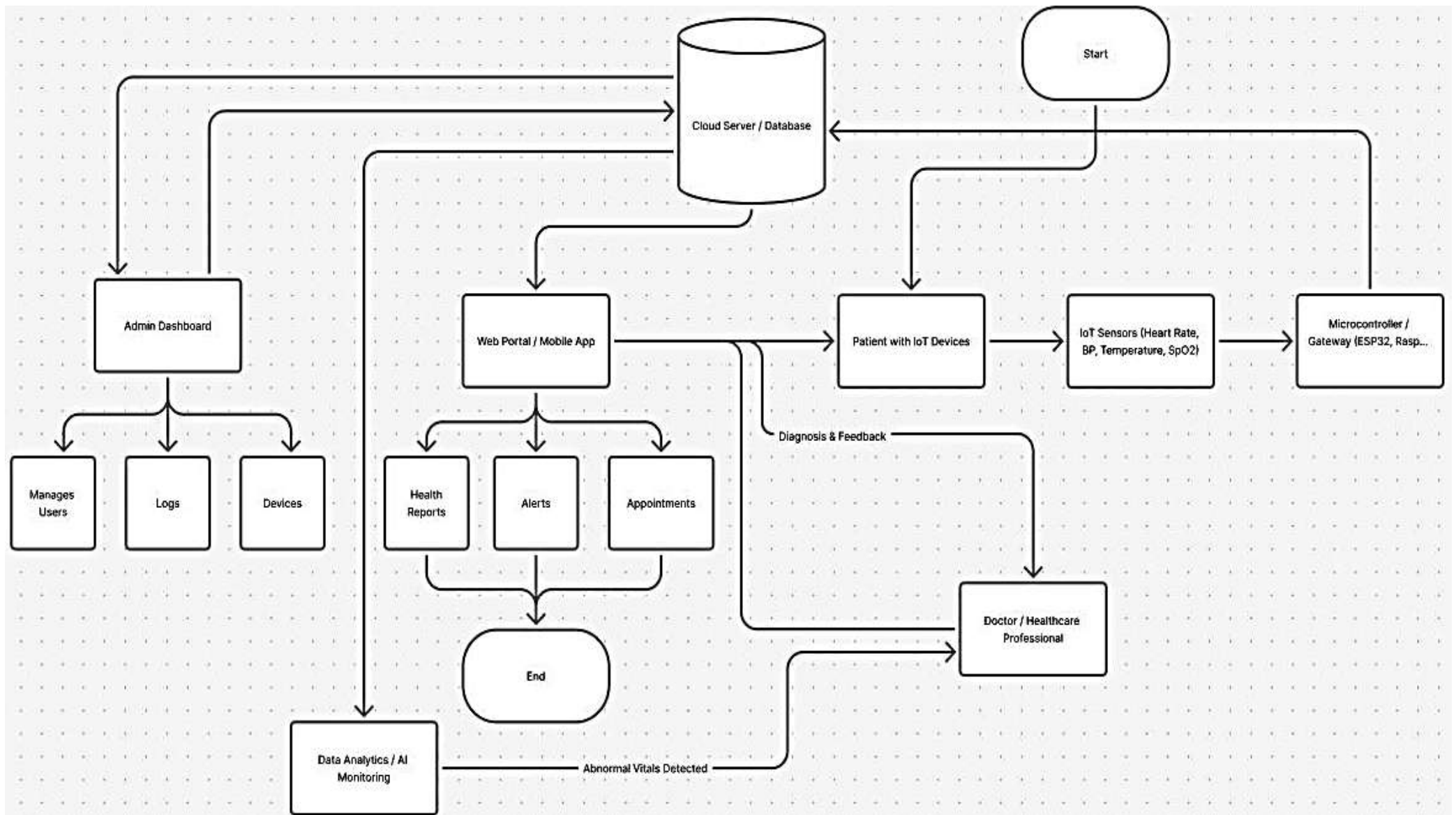

Figure 4: Block Diagram